



Circular duct fans

Rohrventilatoren



VKA

Kanalventilatoren, die für Lüftungs- und Klimaanlage bestimmt sind, werden in das System der runden Luftführungskanäle montiert. Sie werden für Zuluft und -Abluft verwendet. Nicht geeignet für die Beförderung von verschmutzter Luft, aggressiven, explosiven Gasen. Laufrad ist rückwärts gekrümmt, aus Kunststoff oder verzinktem Stahl.

Der Motor: Außenrotor, Direktantrieb, integrierter Thermokontakt-Motorschutz, dauerhafte, keine Pflege erfordernde Lager.

Gehäuse VKA/VKAS 100-315: gestrichen RAL 7035.

VKAS

Kanalventilatoren, die für Lüftungs- und Klimaanlage bestimmt sind, werden an die Wand montiert. Sie werden für Zuluft und Abluft verwendet. Nicht geeignet für die Beförderung von verschmutzter Luft, aggressiven, explosiven Gasen.



VKA

Circular duct fans used for air supply or extract in ventilation and air conditioning systems. Are mounted into a system of round air ducts. Can be installed in any position. Not suitable for polluted air, aggressive and explosive gases.

Impeller with backward curved blades.

Motor: external rotor, motor protection built-in thermal-contact, free-maintenance ball bearings.

VKA/VKAS 100-315 housing: powder coated painting RAL 7035.

VKAS

Circular duct fans used for air extract in ventilation and air conditioning systems. Are mounted on the walls. Not suitable for polluted air, aggressive and explosive gases.

Accessories

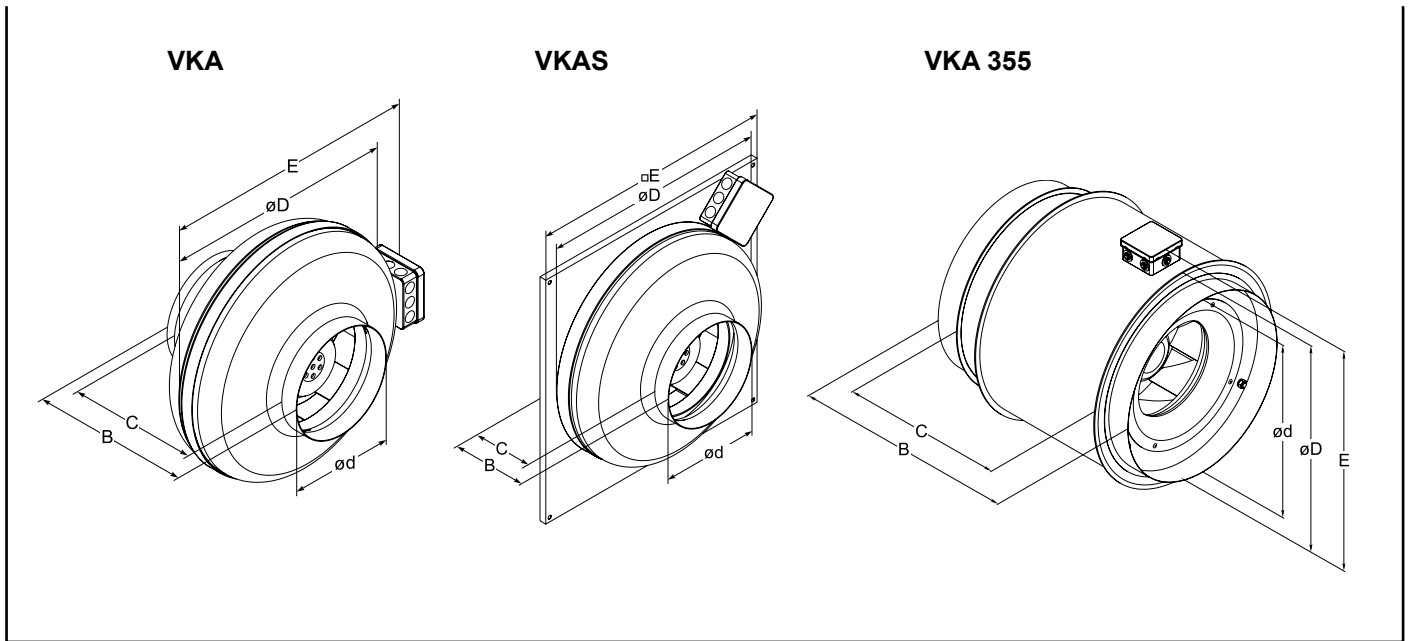

VKA

Type	Dimensions [mm]				
	B	C	øD	ød	E
VKA 100 MD/LD	206±2	167±2	245	100	287
VKA 125 MD/LD	206±2	175±2	245	125	287
VKA 150 LD	227±2	176±2	345	150	389
VKA 160 MD	202±2	153±2	245	160	287
VKA 160 LD	227±2	176±2	345	160	389
VKA 200 MD	219±2	167±2	345	200	389
VKA 200 LD	227±2	175±2	345	200	389
VKA 250 MD	223±2	163±2	345	250	389
VKA 250 LD	230±2	170±2	345	250	389
VKA 315 MD	247±2	179±2	402	315	446
VKA 315 LD	257±2	189±2	402	315	446
VKA 355	450	352	420	354	452

VKAS

Type	Dimensions [mm]				
	B	C	øD	ød	□E
VKAS 100 MD/LD	122	103	242	100	310
VKAS 125 MD/LD	116	101	242	125	310
VKAS 150 LD	129	104	342	150	400
VKAS 160 MD	116	92	242	160	310
VKAS 160 LD	129	104	342	160	400
VKAS 200 MD	123	99	342	200	400
VKAS 200 LD	131	107	342	200	400
VKAS 250 MD	125	100	342	250	400
VKAS 250 LD	131	106	342	250	400
VKAS 315 MD	156	116	400	315	460
VKAS 315 LD	166	126	400	315	460

Accessories

 FDI
p. 164

 EKA
p. 129

 AVS
p. 136

 AVA
p. 146

 TGRV
p. 153

 MTY
p. 156

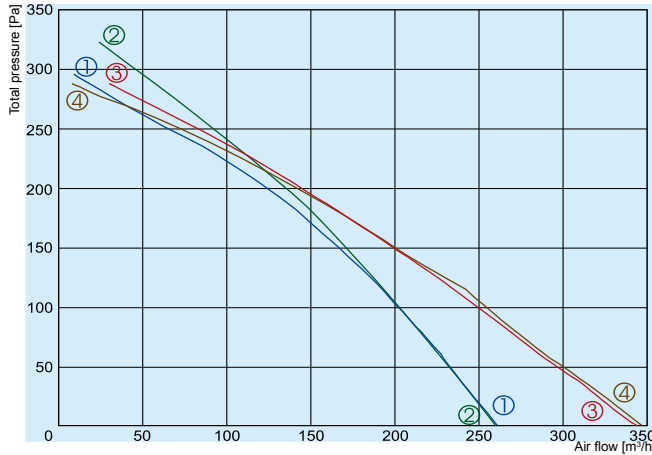

- ① — VKA/VKAS 100 MD
- ② — VKA/VKAS 100 LD
- ③ — VKA/VKAS 125 MD
- ④ — VKA/VKAS 125 LD

		100 MD	100 LD	125 MD	125 LD
Voltage/Frequency	[V/Hz]	230/50	230/50	230/50	230/50
Power consumption	[W]	106	63	107	64
Current	[A]	0,47	0,27	0,47	0,28
Speed	[min ⁻¹]	2546	2478	2494	2409
Max. airflow	[m ³ /h]	261	260	347	344
Max. air temperature	[°C]	40	70	40	70
Total sound pressure level at 1 m	[dBA]	63	63	62	62
Speed controller		TGRV1,5 / MTY0	TGRV1,5 / MTY0	TGRV1,5 / MTY0	TGRV1,5 / MTY0
Weight	[kg]	3 / 2,5	3 / 2,5	3 / 2,5	3 / 2,5
Wiring diagram		No. 2	No. 1	No. 2	No. 1
<i>Protection class:</i>	motor	IP-44	IP-44	IP-44	IP-44
	terminal box	IP-55	IP-55	IP-55	IP-55

100 MD

	L _{pa} dB(A)	L _{wa} total dB(A)	L _{wa} , dB(A)								
			63 Hz	125 Hz	250 Hz	500 Hz	1 kHz	2 kHz	4 kHz	8 kHz	16 kHz
In duct	63	70	40	52	61	61	67	64	57	47	34
Casing break out	43	50	20	32	27	44	55	53	47	35	17

 Measured at 261 m³/h, 0 Pa

100 LD

	L _{pa} dB(A)	L _{wa} total dB(A)	L _{wa} , dB(A)								
			63 Hz	125 Hz	250 Hz	500 Hz	1 kHz	2 kHz	4 kHz	8 kHz	16 kHz
In duct	63	70	37	53	60	60	67	65	57	48	35
Casing break out	43	50	17	33	26	43	55	54	47	36	18

 Measured at 260 m³/h, 0 Pa

125 MD

	L _{pa} dB(A)	L _{wa} total dB(A)	L _{wa} , dB(A)								
			63 Hz	125 Hz	250 Hz	500 Hz	1 kHz	2 kHz	4 kHz	8 kHz	16 kHz
In duct	62	69	38	49	53	61	65	63	55	46	33
Casing break out	45	52	18	27	28	44	53	51	43	32	16

 Measured at 347 m³/h, 0 Pa

125 LD

	L _{pa} dB(A)	L _{wa} total dB(A)	L _{wa} , dB(A)								
			63 Hz	125 Hz	250 Hz	500 Hz	1 kHz	2 kHz	4 kHz	8 kHz	16 kHz
In duct	62	69	38	49	53	61	65	63	55	46	33
Casing break out	45	52	18	27	28	44	53	51	43	32	16

 Measured at 344 m³/h, 0 Pa

The fan characteristic curves were determined in accordance with DIN 24163 resp. ISO 5801. The sound power levels were determined in accordance with DIN 45635 resp. ISO 3744 at a distance of 1 m from the fan

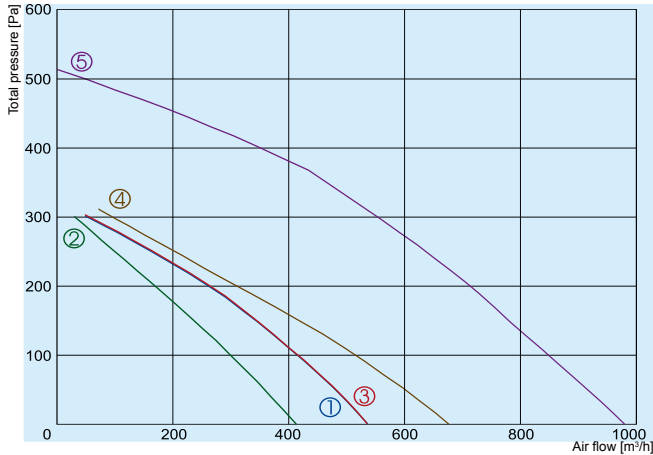

- ① **VKA/VKAS 150 LD**
- ② **VKA/VKAS 160 MD**
- ③ **VKA/VKAS 160 LD**
- ④ **VKA/VKAS 200 MD**
- ⑤ **VKA/VKAS 200 LD**

		150 LD	160 MD	160 LD	200 MD	200 LD
Voltage/Frequency	[V/Hz]	230/50	230/50	230/50	230/50	230/50
Power consumption	[W]	100	65	100	100	162
Current	[A]	0,43	0,28	0,43	0,43	0,71
Speed	[min ⁻¹]	2503	2409	2503	2503	2518
Max. airflow	[m ³ /h]	537	413	537	677	980
Max. air temperature	[°C]	60	70	60	60	75
Total sound pressure level at 1 m	[dBA]	67	61	67	63	66
Speed controller		TGRV1,5 / MTY0	TGRV1,5 / MTY0	TGRV1,5 / MTY0	TGRV1,5 / MTY0	TGRV1,5 / MTY1
Weight	[kg]	4	3 / 2,8	4	4,5 / 4,1	5 / 4,8
Wiring diagram		No. 1	No. 1	No. 1	No. 1	No. 1
Protection class:	motor	IP-44	IP-44	IP-44	IP-44	IP-44
	terminal box	IP-55	IP-55	IP-55	IP-55	IP-55

150 LD

	L _{pa} dB(A)	L _{wa} total dB(A)	L _{wa} , dB(A)								
			63 Hz	125 Hz	250 Hz	500 Hz	1 kHz	2 kHz	4 kHz	8 kHz	16 kHz
In duct	67	74	40	51	67	67	71	63	62	49	37
Casing break out	51	58	20	29	48	50	59	51	50	34	20

Measured at 537 m³/h, 0 Pa

160 MD

	L _{pa} dB(A)	L _{wa} total dB(A)	L _{wa} , dB(A)								
			63 Hz	125 Hz	250 Hz	500 Hz	1 kHz	2 kHz	4 kHz	8 kHz	16 kHz
In duct	61	68	36	47	50	56	64	63	62	49	39
Casing break out	45	52	16	25	20	39	52	51	50	34	22

Measured at 413 m³/h, 0 Pa

160 LD

	L _{pa} dB(A)	L _{wa} total dB(A)	L _{wa} , dB(A)								
			63 Hz	125 Hz	250 Hz	500 Hz	1 kHz	2 kHz	4 kHz	8 kHz	16 kHz
In duct	67	74	40	51	67	67	71	63	62	49	37
Casing break out	51	58	20	29	48	50	59	51	50	34	20

Measured at 537 m³/h, 0 Pa

200 MD

	L _{pa} dB(A)	L _{wa} total dB(A)	L _{wa} , dB(A)								
			63 Hz	125 Hz	250 Hz	500 Hz	1 kHz	2 kHz	4 kHz	8 kHz	16 kHz
In duct	63	70	34	44	53	60	67	62	64	52	39
Casing break out	43	50	12	14	23	40	49	42	53	38	26

Measured at 677 m³/h, 0 Pa

200 LD

	L _{pa} dB(A)	L _{wa} total dB(A)	L _{wa} , dB(A)								
			63 Hz	125 Hz	250 Hz	500 Hz	1 kHz	2 kHz	4 kHz	8 kHz	16 kHz
In duct	66	73	43	53	61	65	69	66	67	62	50
Casing break out	46	53	21	23	31	45	51	46	56	48	37

Measured at 980 m³/h, 0 Pa

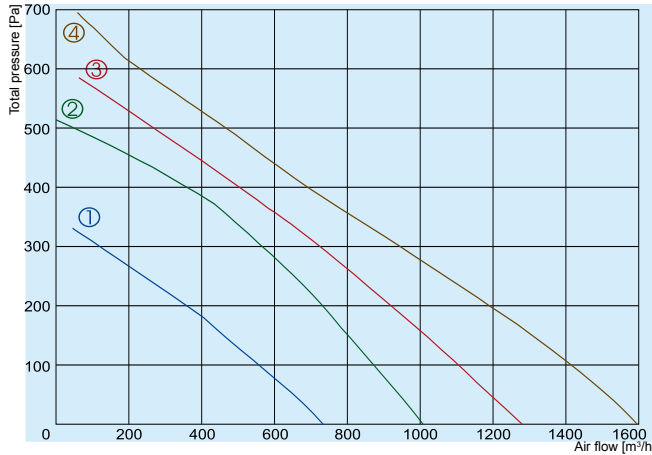

- ① — VKA/VKAS 250 MD
- ② — VKA/VKAS 250 LD
- ③ — VKA/VKAS 315 MD
- ④ — VKA/VKAS 315 LD

		250 MD	250 LD	315 MD	315 LD
Voltage/Frequency	[V/Hz]	230/50	230/50	230/50	230/50
Power consumption	[W]	100	162	217	285
Current	[A]	0,43	0,71	0,96	1,23
Speed	[min ⁻¹]	2505	2518	2437	2266
Max. airflow	[m ³ /h]	733	1008	1280	1596
Max. air temperature	[°C]	60	75	70	45
Total sound pressure level at 1 m	[dBA]	64	68	71	68
Speed controller		TGRV1,5 / MTY0	TGRV1,5 / MTY1	TGRV1,5 / MTY1	TGRV1,5 / MTY2
Weight	[kg]	4,5 / 4,1	5 / 4,9	6,5 / 5,6	6,5 / 6,0
Wiring diagram		No. 1	No. 1	No. 1	No. 1
Protection class:	motor	IP-44	IP-44	IP-44	IP-44
	terminal box	IP-55	IP-55	IP-55	IP-55

250 MD

	L _{pa} dB(A)	L _{wa} total dB(A)	L _{wa} , dB(A)								
			63 Hz	125 Hz	250 Hz	500 Hz	1 kHz	2 kHz	4 kHz	8 kHz	16 kHz
In duct	64	71	34	42	52	59	67	64	66	56	40
Casing break out	44	51	14	19	29	39	47	44	47	38	23

 Measured at 733 m³/h, 0 Pa

250 LD

	L _{pa} dB(A)	L _{wa} total dB(A)	L _{wa} , dB(A)								
			63 Hz	125 Hz	250 Hz	500 Hz	1 kHz	2 kHz	4 kHz	8 kHz	16 kHz
In duct	68	75	44	54	62	66	69	67	67	66	51
Casing break out	48	55	24	31	39	46	49	47	48	48	34

 Measured at 1008 m³/h, 0 Pa

315 MD

	L _{pa} dB(A)	L _{wa} total dB(A)	L _{wa} , dB(A)								
			63 Hz	125 Hz	250 Hz	500 Hz	1 kHz	2 kHz	4 kHz	8 kHz	16 kHz
In duct	71	78	41	53	62	70	75	68	67	68	50
Casing break out	50	57	20	32	40	49	54	49	47	44	24

 Measured at 1280 m³/h, 0 Pa

315 LD

	L _{pa} dB(A)	L _{wa} total dB(A)	L _{wa} , dB(A)								
			63 Hz	125 Hz	250 Hz	500 Hz	1 kHz	2 kHz	4 kHz	8 kHz	16 kHz
In duct	68	75	43	51	61	67	67	68	68	69	54
Casing break out	47	54	22	30	39	46	46	49	48	45	28

 Measured at 1596 m³/h, 0 Pa

The fan characteristic curves were determined in accordance with DIN 24163 resp. ISO 5801. The sound power levels were determined in accordance with DIN 45635 resp. ISO 3744 at a distance of 1 m from the fan

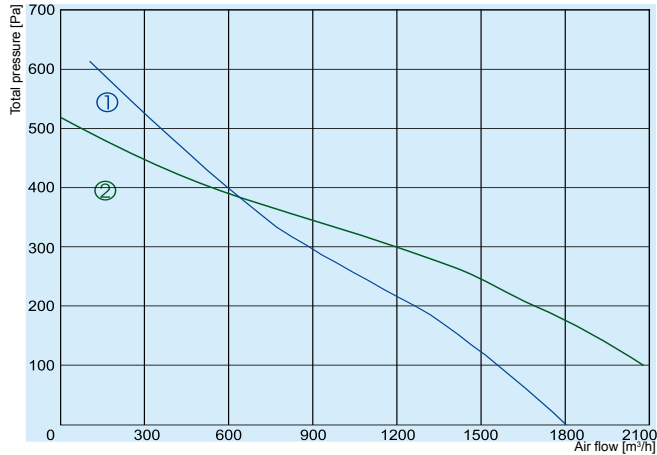

① VKA 355 SD
② VKA 355 MD

		355 SD	355 MD
Voltage/Frequency	[V/Hz]	230/50	230/50
Power consumption	[W]	306	280
Current	[A]	1,33	1,23
Speed	[min ⁻¹]	2595	2650
Max. airflow	[m ³ /h]	1804	2080
Max. air temperature	[°C]	40	50
Total sound pressure level at 1 m	[dBA]	77	76
Speed controller		TGRV1,5 / MTY2	TGRV1,5 / MTY2
Weight	[kg]	11,5	12,0
Wiring diagram		No. 1	No. 3
Protection class:	motor	IP-44	IP-44
	terminal box	IP-55	IP-55

355 SD

	L _{pa} dB(A)	L _{wa} total dB(A)	L _{wa} , dB(A)								
			63 Hz	125 Hz	250 Hz	500 Hz	1 kHz	2 kHz	4 kHz	8 kHz	16 kHz
In duct	70	77	41	48	61	68	70	69	69	72	57
Casing break out	49	56	22	27	39	47	49	50	49	48	31

Measured at 1804 m³/h, 0 Pa

The fan characteristic curves were determined in accordance with DIN 24163 resp. ISO 5801. The sound power levels were determined in accordance with DIN 45635 resp. ISO 3744 at a distance of 1 m from the fan

The company reserves the right to make changes of technical data without prior notice

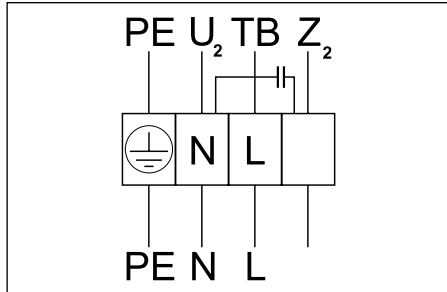

Wiring diagram No. 1 (1~230V)

U₂ - blue or grey
 Z₂ - black
 TB - braun

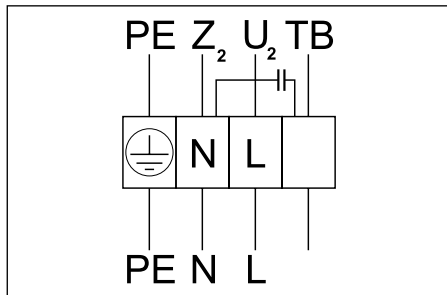

Wiring diagram No. 2 (1~230V)

U₂ - blue or grey
 Z₂ - black
 TB - braun

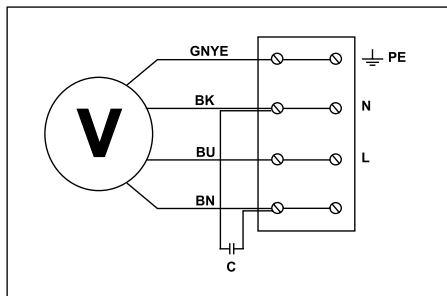

Wiring diagram No. 3 (1~230V)

GNYE - green-yellow
 BK - black
 BU - blue
 BN - brown